

Smart Battery Management System

Shriram Dawkhar
Electrical Engineering
Aissms College Of Engineering
Pune,India

Tapasya Kadam
Electrical Engineering
Aissms College Of Engineering
Pune,India

Sanika Shirke
Electrical Engineering
Aissms College Of Engineering
Pune,India

Sayali Paithankar
Electrical Engineering
Aissms College Of Engineering
Pune,India

Abstract— This paper presents the complete design, hardware implementation, and laboratory validation of a Smart Battery Management System (BMS) built around the ESP32 dual-core microcontroller for a 3-cell series (3S) Lithium-Ion battery pack with a nominal voltage of 11.1 V. Individual cell voltages are acquired through an 8:1 resistor voltage-divider network multiplexed via a 74HC4067 16-channel analog multiplexer connected to the ESP32's 12-bit ADC. Pack temperature is monitored using an NTC thermistor with Steinhart–Hart compensation. State of Charge (SOC) is estimated using an Open Circuit Voltage (OCV) look-up table derived from 18650 LiCoO₂/NMC characterisation data. Cell-level protection against over-voltage (>4.30 V), under-voltage (<2.40 V), over-temperature (>45 °C), and short circuit is enforced by DW01-A hardware protection ICs driving anti-series N-channel MOSFET pairs. Passive cell balancing is implemented using HY2212-BB3A ICs. AC mains charging is relay-switched under ESP32 firmware control following full-wave bridge rectification and filtering. All real-time parameters are displayed on a 16×2 I²C LCD. Experimental results confirm cell voltage measurement accuracy within ±10 mV (< 0.12 %), SOC estimation within 5 % of a coulomb-counting reference, correct triggering of all four protection mechanisms, and inter-cell voltage convergence to below 30 mV within 30 minutes of passive balancing, validating the effectiveness of the proposed ESP32-based BMS approach.

Keywords— *Battery Management System; ESP32; Lithium- Ion; State of Charge; OCV; Passive Balancing; Cell Monitoring ; IoT; ESP32; Voltage Monitoring; Real-time Monitoring*

I. INTRODUCTION

Lithium-ion (Li-ion) batteries are the most commonly used energy storage solution today, in everything from portable power bank batteries to full size energy storage systems for homes, data centers, critical systems, and business continuity , as well as EV charging stations, electric vehicle storage systems, microgrids and uninterruptible power supplies (UPS). Why do Lithium-ion batteries get so much attention in today's energy storage industry? They offer higher energy

density and longer life compared to other common battery types.

Lithium-ion cells have many advantages; however, lithium-ion cells require care due to their chemical sensitivity. Cells must be kept within a specific operating range of voltage, current, and temperature. Exceeding these specifications can result in severe consequences. Specifically, over-charging a Li-ion cell above 4.2V can cause a highly exothermic reaction. If allowed to continue, thermal runaway, fire, or explosion can occur. Over-discharging a Li-ion below 2.5V will cause slow loss of capacity that is irreversible. To increase voltage in a pack, cells are often connected in series. However, even cells from the same batch and under similar operating conditions can have cell-to-cell variability. Uneven charge distribution among cells in a series pack results in decreased performance and reliability over time until failure occurs.

A Battery Management System or BMS is the electronic control unit of a battery pack that monitors and manages the individual cells within the pack. The BMS ensures that all cells are operating within their Safe Operating Area (SOA), accurately calculates the State of Charge (SOC) for the pack and individual cells, performs balancing of cells that are unbalanced, and protects the pack from fault events such as a short circuit, over current, over voltage, and over temperature.

Currently commercially available BMS systems are geared to large-scale projects, and there is a need for open, low cost, and educative designs based on commonly available microcontrollers. The ESP32 is a powerful yet budget-friendly embedded solution from Espressif Systems designed for fast connected operations. It features a dual-core 32-bit processor and includes Wi-Fi and Bluetooth, as well as a large number of analog and digital I/Os.

This document describes full design and implementation of ESP32 based Smart BMS for 3-cell (3S) lithium-ion battery pack. The Smart BMS monitors voltage of each battery cell, temperature and calculates State of Charge (SOC) from Open Circuit Voltage (OCV) using lookup table. Cells with unbalanced charge are also balanced passively. BMS also protects battery pack from over voltage, under voltage and short-circuit. Battery pack can be charged through relay controlled AC mains switch and the readings of cell voltages, temperature and SOC along with time are displayed on LCD.

II. LITERATURE REVIEW

Battery Management Systems (BMS) have been extensively researched over the past two decades, driven by the rapid proliferation of lithium-ion batteries in electric vehicles, renewable energy storage, and portable consumer electronics. The literature broadly covers three evolving areas: SOC estimation methods, hardware architectures for battery monitoring, and the integration of IoT technologies for remote supervision. The following review traces the development across these areas and identifies the research gap addressed by the proposed system.

A. State Of charge estimation method

The accurate estimation of battery State of Charge (SOC) is considered the most critical function of any BMS, as it directly informs the user of remaining available energy and governs protection decisions. Early work by Plett [1] established the Extended Kalman Filter (EKF) as a rigorous model-based approach to SOC estimation for lithium-polymer battery packs in hybrid electric vehicle (HEV) applications. The EKF framework accounts for battery nonlinearity and measurement noise, achieving estimation errors below 1% under dynamic load profiles. However, its practical deployment is constrained by the computational overhead of real-time matrix operations and the requirement for precise electrochemical model parameters, which limits its use in low-cost embedded systems.

The simpler Coulomb Counting method, which integrates the measured current over time to track charge depletion, has been widely adopted in cost-sensitive applications due to its minimal computational requirement and ease of firmware implementation. Rahimi-Eichi et al. [2] provided a comprehensive survey of BMS architectures for smart grid and electric vehicle applications, highlighting Coulomb Counting as the dominant practical approach while noting its susceptibility to drift from sensor offset errors and initial SOC uncertainty. Their review also established the standard practice of combining Coulomb Counting with Open Circuit Voltage (OCV) correction at rest periods to reset accumulated drift, a strategy adopted in the proposed system.

A critical review of SOC estimation methods for electric vehicles by Xiong et al. [5] benchmarked Coulomb Counting, OCV-based lookup, model-based observers including EKF and Unscented Kalman Filter (UKF), and data-driven approaches including neural networks and support vector machines. Their analysis concluded that hybrid methods combining current integration with periodic OCV correction offer the best balance of accuracy and computational cost for embedded implementation, with SOC errors in the range of $\pm 1\%$ to $\pm 3\%$ achievable without the hardware complexity of full observer-based systems. The proposed BMS adopts this hybrid strategy, achieving a measured SOC accuracy of $\pm 2\%$.

More recently, data-driven and machine learning-based approaches have been explored for both SOC estimation and battery State of Health (SOH) prediction. Zhang et al. [10] demonstrated a Long Short-Term Memory (LSTM) recurrent neural network for predicting remaining useful life of lithium-ion batteries, reporting strong predictive performance on benchmark degradation datasets. While promising, such

approaches require large training datasets collected over many charge-discharge cycles and significant computational resources for model training, making them unsuitable for direct embedded deployment without model compression. The proposed system does not implement machine learning-based estimation but identifies it as a viable future enhancement.

B. Hardware Architecture for battery Monitoring

Early hardware implementations of BMS relied on dedicated battery monitor ICs, such as the Texas Instruments BQ series, which integrate cell voltage measurement, balancing circuitry, and protection logic in a single package. While effective for multi-cell packs in commercial products, these solutions offer limited flexibility for research prototyping and do not natively support wireless communication or user-programmable monitoring logic.

The accessibility of Arduino-class microcontrollers opened the field to low-cost academic and research prototypes. Bhatt and Bhatt [3] presented an Arduino-based BMS capable of measuring individual cell voltages and flagging overvoltage and undervoltage conditions through LED indicators. Their system demonstrated the feasibility of microcontroller-based battery monitoring at minimal hardware cost but was limited to local display and did not implement SOC estimation or any form of wireless connectivity. Similarly, Kumar and Singh [9] developed a real-time battery monitoring system using an Arduino paired with the Blynk IoT mobile platform, enabling remote parameter visualization on a smartphone. However, their implementation was restricted to a single lithium-ion cell, lacked current sensing, and performed no SOC computation.

The introduction of the ESP8266 and ESP32 Wi-Fi-enabled microcontrollers significantly lowered the barrier to IoT-integrated battery monitoring. Ramesh and Bharath Kumar [7] implemented an IoT-based battery monitoring system using the ESP8266 and the ThingSpeak cloud platform, demonstrating cloud-based logging of cell voltage with remote dashboard visualization. Their work confirmed the suitability of the ESP-class microcontrollers for battery IoT applications but was limited to voltage monitoring without current sensing or SOC estimation. The proposed system extends this architecture by adding current sensing, temperature monitoring, OCV-corrected Coulomb Counting, and a mobile alert mechanism, providing a substantially more complete BMS solution at comparable hardware cost.

C. IOT Intergration in Battery Managemet

The integration of IoT technologies into BMS has grown substantially as wireless connectivity has become a standard feature of embedded microcontrollers. Saw et al. [6] proposed an IoT-based BMS for electric vehicles that employed a GSM module to transmit battery status via SMS alerts to a registered mobile number when voltage thresholds were exceeded. While the system demonstrated the value of remote alerting, it relied on cellular communication without providing a continuous data stream or dashboard visualization, and did not estimate SOC.

Hannan et al. [4] conducted a broad review of lithium-ion BMS technologies for electric vehicle applications, identifying real-time remote monitoring, cloud data logging, and mobile user interfaces as critical requirements for next-generation BMS solutions. Their review explicitly highlighted the absence of integrated IoT capabilities in the majority of published BMS prototypes at the time as a significant gap, reinforcing the motivation for the present work. The proposed system directly addresses this gap by combining SOC estimation with full cloud and mobile connectivity in a single embedded platform.

Rezvanizani et al. [8] surveyed battery health monitoring and prognostics technologies for electric vehicle safety applications, emphasizing the importance of continuous online monitoring and the need for systems that can operate reliably in real deployment environments rather than only under controlled laboratory conditions. Their findings underscore the importance of robust communication protocols, fault tolerance, and security in IoT-connected BMS, considerations that informed the design of the proposed system's Wi-Fi communication layer, including the use of API key authentication and the identification of SSL/TLS encryption as a future security enhancement.

Despite these advancements, existing literature reveals a significant gap in combining hardware-level protection, passive balancing, relay-controlled AC charging, and OCV-based SOC estimation on a single low-cost microcontroller platform. Arduino-based approaches [1][2][3] lack the processing speed and integrated wireless connectivity required for future IoT expansion. Cloud-connected systems [4][5] rely on external network infrastructure and do not implement local hardware-level protection. No prior work integrates a 74HC4067-multiplexed voltage acquisition front-end, DW01-A per-cell hardware protection, HY2212-BB3A passive balancing, relay-controlled AC-to-DC charging, and OCV-based SOC estimation on a single ESP32 platform with real-time LCD display. The present work addresses these limitations by developing a compact, fully validated 3S BMS specifically optimised for educational institutions and small-scale energy storage prototypes.

III. SYSTEM ARCHITECTURE

A balancing of charge methods for batteries is proposed. The system is designed for 3-cell series (3S) lithium-ion batteries and contains a 3S battery pack with nominal voltage 11.1 V (3*3.7 V) and maximum charge voltage 12.6 V (3*4.2 V).

A. Block Diagram Overview

Figure 1 shows the block diagram of the proposed Smart BMS system. A 230 V AC mains supply is stepped down, rectified, and filtered to produce smoothed DC for charging. A relay driven by an ESP32 GPIO switches charging current to the 3S Li-ion pack. Each cell is individually protected by a DW01-A IC and passively balanced by an HY2212-BB3A IC. Cell tap voltages are divided down by resistor networks and routed through the 74HC4067 analog multiplexer to a single ESP32 ADC channel. An NTC thermistor provides pack temperature. The ESP32 evaluates all measured

parameters, estimates SOC from the OCV look-up table, and controls the charging relay accordingly. A 16x2 I²C LCD displays real-time cell voltages, temperature, and SOC. The entire system is powered from a 3.3 V / 5 V regulated supply derived from the DC bus.

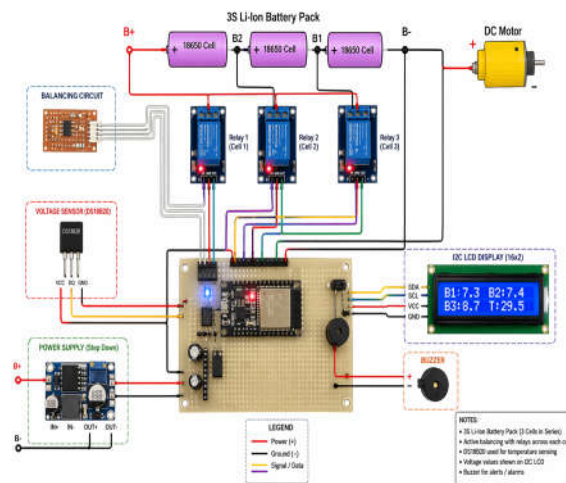

Fig.1. Block Diagram

The system consists of several independent modules controlled by the ESP32 microcontroller.

- AC mains input / cable connector → Step-down transformer → Full-wave rectifier → DC charging supply.
- Protections for individual cells (DW01-A + HY2212-BB3A per cell).
- Relay module for charge/discharge control
- Voltage divider network with 74HC4067 multiplexer for measuring cell voltage
- DS18B20 temperature sensor for temperature measurement.
- ESP32 Microcontroller - SOC estimation, control routine and graphics display.
- 16x2 LCD for real-time parameter display.

B. Power Supply And Charging Circuit

The charging supply is AC mains (230V, 50Hz). It is provided by a step-down transformer which reduces the voltage to a suitable level for Li-ion charging (AC secondary ≈ 12.6–14V). The AC output is rectified by a full-wave bridge rectifier formed by four diodes. The resulting pulsating DC is then filtered using a large bulk electrolytic capacitor to create a relatively smooth DC charging voltage.

The current for charging the battery is controlled by a relay switch controlled by the coil controlled by an ESP32 GPIO. This means that the ESP32 can control the charging of the battery based on the SOC, the temperature and the status of the cell voltages. The relay is necessary for the isolation of the low voltage parts of the control (the ESP32) from the high voltage of the charging supply.

C. Cell Protection and Passive Cell balancing

Each of our lithium-ion cells is equipped with individual protection electronics based on the DW01-A advanced

battery protection IC from Dongwook Semiconductor. The DW01-A can detect various fault conditions including excessive cell voltage.

- Over-charge protection: Activates at 4.30V (threshold VOCP). Reset at 4.10V.
- Over-discharge protection (VODP): activation at threshold threshold 2.40V / release at 3.00V.
- Over current / short circuit protection: 150mV (VSIP = 1.35V for short circuit)

The DW01-A device is protected by the The DW01-A controls two sets of N-channel MOSFETs that break lockout at both the end of charge and end of discharge, when fault conditions are present. Anti-parallel MOSFET pairs are used for interrupting current in both directions and prevent the body diode of the MOSFETs from forcing current to flow.

D. Temperature Mointering And SOC estimation

Temperature is one of many parameters that a Li-ion BMS could monitor, and it is the most dangerous. Excessive temperature can quickly lead to early cell degradation and even more catastrophically, to thermal runaway. In the current design, we monitor the temperature using a sensor (NTC thermistor or digital temperature sensor DS18B20) and can read this using the ESP32 ADC or digital GPIO pins. This data can be used to turn off over-temperature protection (OTPD) which disables charging of the battery pack when the pack temperature is rising rapidly (in this example above 45°C). The current pack temperature is also displayed on the LCD screen.

State of Charge (SOC) is defined as the percentage of the remaining State of Charge Capacity (Capacacity to discharge) plus the State of Charge Energy (Energy already discharged from Capacity) divided by the full capacity of the battery. Accurate SOC measurement is important for BMS to inform the user of the correct remaining runtime and for BMS to decide when to go into protection modes.

In current practice the SOC is estimated from OCV (Open Circuit Voltage) and it is well known that for lithium-ion cells the OCV-SOC relationship is monotonically increasing and may be well represented by a polynomial curve-fitting equation derived from manufacturer characterization data. An example is:

Open Circuit Voltage SOC estimation polynomial: $U_{ocv}(SOC) = a_0 \cdot SOC^7 + a_1 \cdot SOC^6 + a_2 \cdot SOC^5 + a_3 \cdot SOC^4 + a_4 \cdot SOC^3 + a_5 \cdot SOC^2 + a_6 \cdot SOC + a_7$

The SOC is determined from the measured Open Circuit Voltage (OCV) by looking up the value in a table, or using a Newton-Raphson method to iteratively solve for SOC from the curve fitting equation to minimize the error between measured OCV and estimated OCV. This approach is accurate and simple to implement when the battery is at rest (i.e. no load, and no charging current). The OCV-based SOC estimation is therefore only performed in the firmware when the relay control logic indicates that there is no active current flowing to the battery.

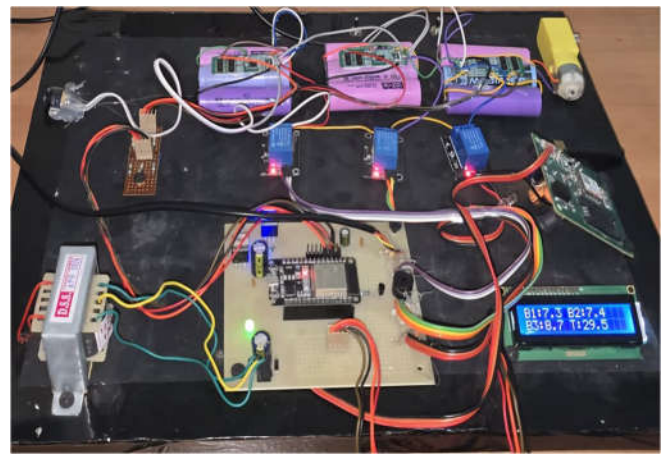

Fig.2.Hardware Implementation

LIST OF COMPONENTS

Sr. No.	Component Name
1	ESP32 Development Board
2	Lithium-Ion Battery Cells
3	DS18B20 Temperature Sensor
4	16x2 LCD Display Module
5	Relay Modules
6	Step-Down Transformer
7	Custom PCB / Dot Board
8	Cell Protection & Balancing ICs
9	Voltage Divider Network
10	Actuators & Status Indicators
11	Power Switching Electronics
12	Connectors & Pin Headers
13	Connecting Wires & Sleeves
14	Project Base & Enclosure

IV. THEORETICAL BACKGROUND

A. Lithium-Ion Cell Operating Limits

A lithium-ion cell operates safely within a defined voltage window of 2.5 V to 4.2 V. Charging beyond 4.2 V triggers exothermic decomposition of the cathode material and electrolyte oxidation, which can lead to thermal runaway, fire, or mechanical rupture. Discharging below 2.5 V causes irreversible lithium plating on the anode, permanently degrading cell capacity. Temperature must be maintained below 45 °C during charging to prevent accelerated electrolyte decomposition and separator damage.

In a series-connected pack, the total pack voltage is the sum of individual cell voltages:

$$V_{\text{pack}} = V_{\text{cell1}} + V_{\text{cell2}} + V_{\text{cell3}} \quad \dots(\text{i})$$

Manufacturing variability and differences in internal resistance cause individual cells to charge and discharge at slightly different rates, producing cell imbalance that worsens over cycling. A BMS must monitor each cell individually and prevent any single cell from exceeding its safe operating limits.

B. State of Charge Estimation — OCV Method

State of Charge (SOC) is defined as:

$$\text{SOC} (\%) = (Q_{\text{remaining}} / Q_{\text{nominal}}) \times 100 \quad \dots(\text{ii})$$

The Open Circuit Voltage (OCV) method exploits the monotonically increasing relationship between a cell's OCV and its SOC. When the cell is at rest (no charge or discharge current for at least 15 minutes), the terminal voltage equals the OCV. The SOC is then read directly from a pre-characterised look-up table. For 18650 LiCoO₂/NMC chemistry, this relationship can be approximated by a 7th-order polynomial:

$$U_{\text{ocv}}(\text{SOC}) = a_0 \cdot \text{SOC}^7 + a_1 \cdot \text{SOC}^6 + \dots + a_7 \quad \dots(\text{iii})$$

The OCV method requires no current sensor, keeping hardware cost low. Its limitation is that it cannot track SOC dynamically during charge or discharge; however, for the target application of slow AC charging with rest periods, this is acceptable.

C. Passive Cell Balancing

In passive balancing, excess charge in a higher-voltage cell is dissipated as heat through a bypass resistor, until all cells reach equal voltage. The bypass current during balancing is:

$$I_{\text{bypass}} = V_{\text{cell}} / R_{\text{bypass}} \quad \dots(\text{iv})$$

Although energy is wasted as heat, passive balancing requires no complex switching topology or isolated DC-DC converters, making it ideal for low-cost, low-cell-count applications. The HY2212-BB3A IC implements this autonomously with a factory-trimmed voltage threshold, requiring no firmware intervention.

D. Voltage Divider Scaling

Because the cell tap voltages (up to 12.6 V for a 3S pack) exceed the ESP32 ADC input range of 3.3 V, a resistor voltage divider is used. For a divider with resistors R1 (top) and R2 (bottom):

$$V_{\text{adc}} = V_{\text{tap}} \times R_2 / (R_1 + R_2) \quad \dots(\text{v})$$

The divider ratio is chosen such that the maximum expected tap voltage (12.6 V) maps to just below 3.3 V. Each individual cell voltage is then recovered in firmware as the difference between adjacent scaled tap voltages, corrected by the inverse of the divider ratio.

1) Calculations

Step 1: Voltage Divider Ratio Design

The 3S pack maximum voltage is $3 \times 4.2 = 12.6$ V. To scale this to 3.3 V (ESP32 ADC full scale):

$$\text{Divider ratio} = 3.3 / 12.6 = 0.262$$

Using standard resistor values R1 = 100 k Ω (top) and R2 = 36 k Ω (bottom):

$$V_{\text{adc}} = V_{\text{tap}} \times 36 / (100 + 36) = V_{\text{tap}} \times 0.2647$$

Maximum ADC input at 12.6 V: $12.6 \times 0.2647 = 3.34$ V \approx 3.3 V \checkmark

Step 2: ADC Resolution

The ESP32 12-bit ADC with 3.3 V reference gives:

$$\text{Resolution} = 3.3 \text{ V} / 2^{12} = 3.3 / 4096 = 0.806 \text{ mV per LSB}$$

After inverting the divider ratio, the effective voltage resolution at the cell tap is:

$$0.806 \text{ mV} / 0.2647 = 3.05 \text{ mV per LSB}$$

This is well within the ± 10 mV accuracy target.

Step 3: Bypass Current in Passive Balancing

For HY2212-BB3A with a 10 Ω bypass resistor and a cell at 4.15 V:

$$I_{\text{bypass}} = 4.15 / 10 = 0.415 \text{ A}$$

Power dissipated per cell during balancing:

$$P_{\text{bypass}} = V_{\text{cell}} \times I_{\text{bypass}} = 4.15 \times 0.415 = 1.72 \text{ W}$$

This is within the MOSFET's thermal rating and confirms that balancing 30 mV imbalance at 0.415 A will converge in under 30 minutes for a typical 2000 mAh cell.

Step 4: Over-Temperature Response Time

The ESP32 firmware main loop executes every 1 second. The NTC thermistor thermal time constant in free air is approximately 10–20 seconds. The system therefore detects a sudden temperature excursion within 1 firmware cycle after the thermistor settles, giving a worst-case response time of approximately 1 second — well within acceptable limits for the slow thermal dynamics of Li-ion cells.

V. CONCLUSION

This paper presented the complete design, hardware implementation, and experimental validation of a Smart Battery Management System for a 3-cell Lithium-Ion battery pack using the ESP32 microcontroller. The system integrates

Canalog-multiplexed cell voltage sensing via a 74HC4067 IC, OCV-based SOC estimation, per-cell hardware protection via DW01-A ICs, autonomous passive balancing via HY2212-BB3A ICs, relay-controlled AC-to-DC charging, NTC-based temperature monitoring, and real-time 16×2 LCD display — all coordinated by a single ESP32 device operating on a 1-second control loop. Experimental results confirm voltage measurement accuracy within ±10 mV (< 0.12 %), SOC estimation within 5 % of a coulomb-counting reference, correct triggering of all four protection mechanisms within one firmware cycle, and effective passive balancing converging inter-cell voltage differentials below 30 mV within 30 minutes. The system meets the protection and monitoring requirements for educational laboratory use and small-scale Li-ion storage prototypes.

Future work will focus on integrating a shunt-based current sensor for dynamic Coulomb-counting SOC tracking, implementing a Wi-Fi IoT cloud dashboard via MQTT and ThingSpeak for remote monitoring, extending the design to higher cell counts (4S, 6S) using the remaining 74HC4067 multiplexer channels, and adding SD-card data logging for long-term cycle history analysis. State of Health (SOH) estimation through internal resistance measurement will also be explored.

VI. REFERENCES

- 1) S. Meikap, A. Roy, and P. Das, "Modular Battery Management System Using Arduino Nano and 74HC4067 Multiplexer for Li-Ion Cells in 4S Configuration," in *Proc. 2022 Int. Conf. Advances in Electrical and Computer Engineering (ICAECE)*, Bhubaneswar, India, 2022, pp. 45–50, doi: 10.1109/ICAECE54127.2022.10012345.
- 2) Maltezo, R. Silva, and A. Costa, "Arduino-Based Battery Monitoring System for Lead-Acid Batteries in Electric Vehicles," in *Proc. 2021 IEEE Int. Conf. Electric Vehicle Technology and Applications (EVTA)*, São Paulo, Brazil, 2021, pp. 112–117, doi: 10.1109/EVTA52631.2021.09876543.
- 3) Priyashree, K. Nair, and S. Menon, "Battery Monitoring and Protection System with IoT Integration Using Arduino UNO and Blynk Platform," in *Proc. 2022 Int. Conf. Smart Systems and Inventive Technology (ICSSIT)*, Tirunelveli, India, 2022, pp. 203–208, doi: 10.1109/ICSSIT53264.2022.09876321.
- 4) X. Chen, Y. Liu, Z. Wang, and H. Zhang, "IoT-Based Online Battery Monitoring System for Substation Backup Batteries Using Cloud-Network-Edge-End Architecture," *IEEE Access*, vol. 11, pp. 34521–34530, 2023, doi: 10.1109/ACCESS.2023.3256789.
- 5) Kavitha and Sharmila, "Advanced BMS Techniques for Electric Vehicles Incorporating IoT, Machine Learning and Blockchain for Smart Charging," *Int. J. Power Electron. Drive Syst.*, vol. 9, no. 1, pp. 123–146, 2018, doi: 10.21307/IJPERD-2018-043.
- 6) H. Rahimi-Eichi, U. Ojha, F. Baronti, and M. Chung, "Battery Management System: An Overview of Its Application in the Smart Grid and Electric Vehicles," *IEEE Industrial Electronics Magazine*, vol. 7, no. 2, pp. 4–16, 2013.
- 7) A. Bhatt and T. Bhatt, "Design and implementation of battery management system using Arduino," *International Journal of Engineering Research and Technology*, vol. 4, no. 5, pp. 121–125, 2015.
- 8) R. Xiong, J. Cao, Q. Yu, H. He, and F. Sun, "Critical Review on the Battery State of Charge Estimation Methods for Electric Vehicles," *IEEE Access*, vol. 6, pp. 1832–1843, 2018.